

LOC	DIST	REVISIONS					
GP	00	P	LTR	DESCRIPTION	DATE	DWN	APVD
			E2	REVISED PER ECO-06-029824	10JAN07	JDP	SAS

- ① 10.16[.400] MAX CABLE DIA.
- ② ZINC PER ASTM AG40A, UNS Z33521.
- ③ NICKEL PLATED.
- ④ STEEL PER ASTM A109.
- ⑤ BRIGHT TIN-LEAD PLATED.
- ⑥ FLAME RETARDANT 94 V-0 RATED, POLYOLEFIN OR PVC, COLOR: BLACK.
- ⑦ BLACK ZINC PLATED.
- ⑧ BRIGHT TIN PLATED.

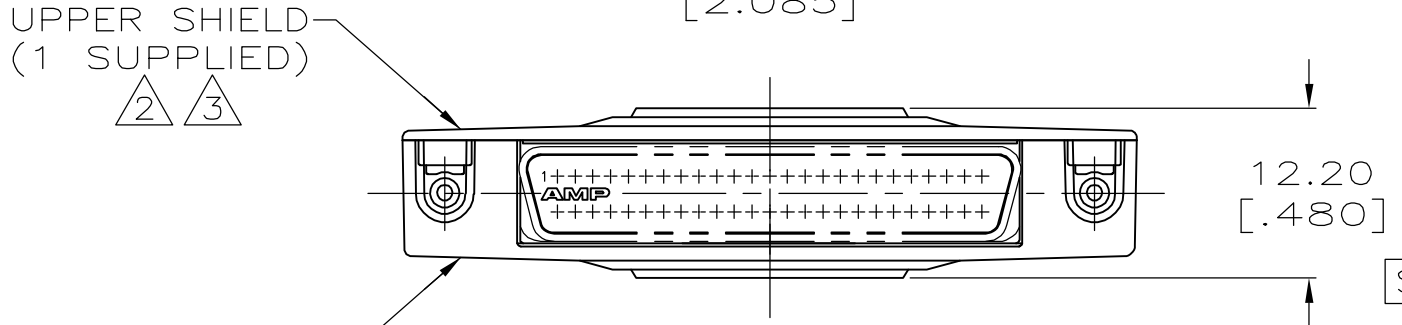
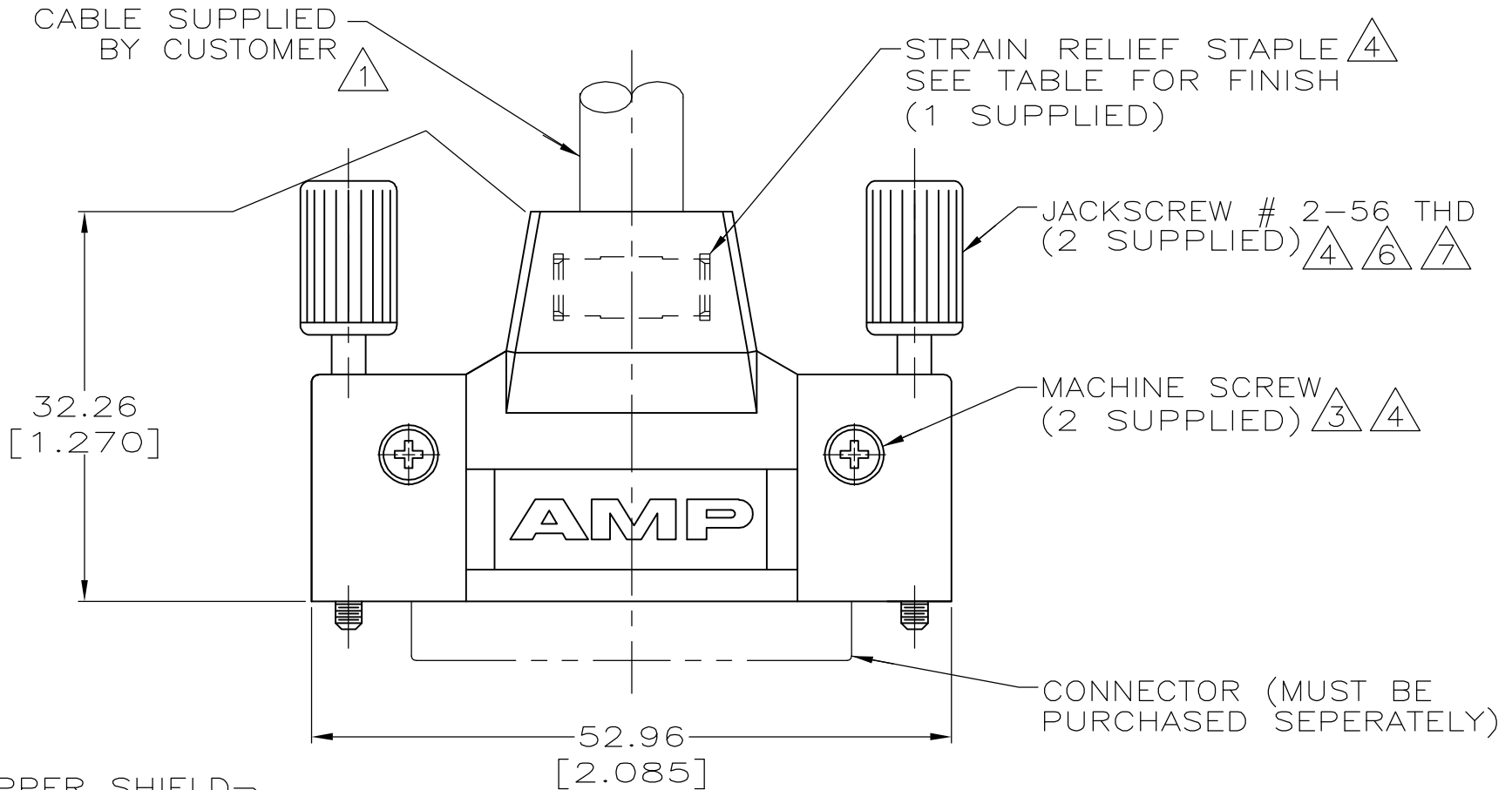

SUPERSEDED BY 5749080-1	KIT	⑧	749080-3
OBSOLETE	BULK	⑤	749080-2
	KIT	⑤	749080-1
	PACKAGING	STAPLE	PART NO

THIS DRAWING IS A CONTROLLED DOCUMENT.		DWN JACK ROOT 11-23-88	<b>tyco</b> Tyco Electronics Corporation	
DIMENSIONS: mm[INCHES]		CHK M.WATERS 12-1-88	<b>Electronics</b> Harrisburg, PA 17105-3608	
TOLERANCES UNLESS OTHERWISE SPECIFIED:		APVD -	NAME	
0 PLC ± -		PRODUCT SPEC -	BACKSHELLS WITH MALE JACKSCREWS,50 POSITION	
1 PLC ± -		APPLICATION SPEC -	AMPLIMITE .050 Series	
2 PLC ± 0.38 [.015]		WEIGHT -	SIZE A3	RESTRICTED TO -
3 PLC ± -		CUSTOMER DRAWING	CAGE CODE 00779	
4 PLC ± -			DRAWING NO C-749080	
ANGLES ± -			SCALE 2:1	
MATERIAL -	FINISH -		SHEET 1 of 1	REV E2